



RODCRAFT®

Tools and Workshop Equipment

CATALOGUE

2024



NEW
Battery
Impact
wrenches

*More details on
the innerpages*

TABLE OF CONTENT

Battery products	NEW	Pages 4 – 5
Impact wrenches		Pages 6 – 9
Torque wrenches & sockets		Page 10
Ratchets		Page 11
Rodflex-Tools	NEW	Page 12
Mini tools		Page 13
Drills & screwdrivers		Pages 14 – 15
Chisel hammers & needle scalers		Pages 16 – 17
Sanders		Pages 18 – 21
MBX Multi Sander	NEW	Page 22
Polishers		Page 23
Special tools & cutting		Page 24
Riveters		Page 25
Other pneumatic tools		Pages 26 – 27
Capacitor jump-starter		Page 28
Car jacks		Pages 29 - 31
Workshop equipment		Page 32
Workshop presses		Page 33
Air line accessories		Pages 34 - 35

OUR LATEST PRODUCT HIGHLIGHTS

More Details to explore on the innerpages



MBX Multi Sander

For all kinds of surface preparation

More details page 22



January 2024

Pneumatic Rodflex-Tools

Ratchets & Cut-off tool with flex-head

More details page 12



Gear driven Pneumatic Saw

Ensure a safe cutting experience with the RC6070, featuring keyless blade change, guards to prevent slipping and a low-vibration.

More details page 24



April 2024

Battery Impact wrenches

1/2" and 3/4"

More details page 4-5



April 2024

For product updates and latest news please check our Website.

WWW.RODCRAFT.COM

BATTERY Impact wrenches

Brushless & Powerful for a wide range of vehicle service/ mechanics applications



MODEL	RC9067	RC9077	RC9087
Item number (Bare tool without battery)	8951000464	8951000465	8951000466
Rated Voltage (V)	20	20	20
Max. Free Speed (rpm)	2600	1700	1700
Max. loosening torque (Nm)	500	1500	1500
Output drive size (inch)	1/2	1/2	3/4
Speed Range (rpm)	0 to 2600	0 to 1700	0 to 1700
Impact Rate Range (bpm)	0 to 3500	0 to 2200	0 to 2200
Bare Tool Weight* (kg)	1.2	3	3.05
Bare Tool Length (L) (mm)	137	230	230
Bare Tool Width (W) (mm)	80	87	87
Bare Tool Height (H) (mm)	210	245	245
Recommended Charging Temperature (°C)	0 to +45	0 to +45	0 to +45
Storage Temperature (°C)	20 to +50	20 to +50	20 to +50
Operating Temperature (°C)	-20 to +70	-20 to +70	-20 to +70

Choose from 3 battery variants: 2Ah, 4Ah and 6Ah
All 3 Batteries (2Ah, 4Ah and 6Ah) are compatible with the 3 Tools. Allowing to make multiple combinations according to customer's needs.



The following sets are available as a package

	RC9067K2	RC9077K4	RC9077K6	RC9087K4	RC9087K6
Item number	8951000473	8951000474	8951000476	8951000475	8951000477
Model	RC9067	RC9077	RC9077	RC9087	RC9087
Batteries	2 x 2 Ah	2 x 4 Ah	2 x 6 Ah	2 x 4 Ah	2 x 6 Ah
Charger	✓	✓	✓	✓	✓
Soft bag	✓	✓	✓	✓	✓



We proudly present a NEW Product Range for Rodcraft: the RC90 Series of Battery Tools.

The new 3 Battery Impact Wrenches RC9067 (1/2"), RC 9077 (1/2"), RC9087 (3/4") are only the beginning of a new high quality set of battery tools.

NEW



Battery brushless impact wrench 1/2"

Model RC9067

Item no.: 8951000464

Compact Impact Wrench for daily vehicle service with 500 Nm maximum torque in rev. Only 1.6 kg including battery, measures 137 mm for easy maneuvering 3 power settings forward and 2-stage trigger for precise control.



Battery brushless impact wrench 1/2"

Model RC9077

Item no.: 88951000465

Battery version of our famous RC2277 Model.

1500 Nm maximum torque in reverse. For general mechanic applications. 3 power settings, 2 stage trigger for precision, BRUSHLESS, 2 component handle, LED light, integrated hard rubber bumper protection for tool and battery, HEAVY DUTY.



Battery brushless impact wrench 3/4"

Model RC9087

Item no.: 8951000466

1500 Nm maximum torque in reverse. For general mechanic applications. 3 power settings, 2 stage trigger for precision, BRUSHLESS, 2 component handle, LED light, integrated hard rubber bumper protection for tool and battery, HEAVY DUTY.

Product picture alike. For products that are not purchased in a set (see page 4 table below), the battery and charger not included.



Pneumatic impact wrench 1/2"
Model RC22277

Item no.: 8951000349

THE BEAST

The RC2277 1/2" impact wrench is the ideal choice for users who work with tire changes or industrial maintenance and are looking for the best performance, high robustness and the optimal comfort.



Pneumatic impact wrench 3/8"
Model RC2177

Item no.: 8951000043

Ergonomic and lightweight tool with very good weight distribution. Non-slip and shock-absorbing handle, high performance for quick disassembly with low compressed air requirement.
 Compact design for confined spaces. Durable DUOPACT hammer mechanism



Pneumatic impact wrench 1/2"
Model RC2203

Item no.: 8951000387

The RC2203 is known for its ultra-compact design and its high performance. It is the best choice for users working in hard-to-reach places and looking for an excellent power-to-weight ratio.



Pneumatic impact wrench 1/2"
Model RC2205

Item no.: 8951000085

The popular classic. One-hand operation with left/right switch and 4-stage power regulation when tightening Full power when loosening - max. 800 Nm. Attachment option for sound-absorbing hose



Pneumatic impact wrench 1/2"
Model RC2267

Item no.: 8951000044

Ergonomic and lightweight tool with very good weight distribution. Non-slip and shock-absorbing handle, high performance for quick disassembly with low compressed air requirement. Compact design for confined spaces.



Pneumatic impact wrench 1/2"
Model RC2266

Item no.: 8951000436

The RC2266 1/2" impact wrench is impressive with its versatility, its excellent price-performance ratio and the well-known RODCRAFT quality.



Recommended accessories
SOCKET SET
 See page 10





Angle impact wrench 1/2"
Model RC2235

Item no.: 8951000286

Low profile angle impact wrench with ergonomic grip. Ultra-compact head (only 50 mm). Durable with reinforced head and helical gearing

High sensitivity pusher, torque adjustment, easy forward/reverse switching.



Pneumatic impact wrench 3/4"

Model RC2377

Item no.: 8951000045

Ergonomic tool with very good weight distribution (best weight/power ratio in its class). Non-slip and shock-absorbing handle and durable DUOPACT hammer mechanism.



Pneumatic impact wrench 3/4"

Model RC2315

Item no.: 8951077130

All-rounder for every application. DUOPACT hammer mechanism, 3-stage power reduction when tightening. Handle with insulating rubber coating.



MODEL	RC2277	RC2203	RC2267	RC2205	RC2266	RC2235	RC2177	RC2377	RC2315
Item number	8951000349	8951000387	8951000044	8951000085	8951000436	8951000286	8951000043	8951000045	8951077130
Output drive size	1/2"	1/2"	1/2"	1/2"	1/2"	1/2"	3/8"	3/4"	3/4"
Max. loosening torque	1,950 Nm	1,254 Nm	1,150 Nm	800 Nm	1,600 Nm	450 Nm	950 Nm	2,200 Nm	1,700 Nm
Max. torque in reverse	1,300 Nm	650 Nm	660 Nm	580 Nm	1,000 Nm	300 Nm	580 Nm	1,950 Nm	1,500 Nm
Working torque range (forward)	60–900 Nm	90–450 Nm	22–486 Nm	34–420 Nm	140–750 Nm	60–220 Nm	37–258 Nm	234–1,391 Nm	177–1,100 Nm
Free speed	8,200 rpm	10,500 rpm	10,200 rpm	7,800 rpm	9,000 rpm	7,400 rpm	8,200 rpm	5,760 rpm	5,600 rpm
Impact mechanism	DUOPACT	Twin Hammer	DUOPACT	Pin clutch	DUOPACT	Jumbo hammer	DUOPACT	DUOPACT	DUOPACT
Air intake thread size	1/4"	1/4"	1/4"	1/4"	1/4"	1/4"	1/4"	3/8"	3/8"
Noise level	94 dB(A)	90 dB(A)	93 dB(A)	87.4 dB(A)	96.4 dB(A)	97 dB(A)	90 dB(A)	96.8 dB(A)	91.1 dB(A)
Length	194 mm	115 mm	164 mm	200 mm	185 mm	341 mm	164 mm	221 mm	242 mm
Weight	2 kg	1.1 kg	1.25 kg	2.4 kg	2.18 kg	1.85 kg	1.25 kg	3.5 kg	4.7 kg

Pneumatic impact wrench 1"

Model RC2405

Item no.: 8951000075



The RC2377/RC2405 range of impact wrenches is the perfect companion for vehicle and tire services with their excellent power-to-weight ratio and ergonomics.

Pneumatic impact wrench 1"

Model RC2437Xi

Item no.: 8951000068



The RC2437Xi range contains the perfect 1" impact wrenches for workshops looking for low weight and high torque

Pneumatic impact wrench 1"

Model RC2461

Item no.: 8951000354

Short anvil



Take advantage of the benefits of the 1" RC2461 and RC2471 impact wrenches.

They enable the operator to easily loosen wheel nuts on commercial vehicles.

These 1" impact wrenches offer high reliability thanks to their durable impact mechanism and metal housing.

Pneumatic impact wrench 1"

Model RC2471

Item no.: 8951000355

Long anvil



Pneumatic impact wrench 1"

Model RC2457Xi

Item no.: 8951000135

Short anvil



The RC2457Xi and RC2477Xi models are perfect for tightening and loosening wheel nuts on commercial vehicles.

The low weight and the compact design also offer you a high level of comfort in your daily work and ultimately increase your productivity.

Pneumatic impact wrench 1"

Model RC2477Xi

Item no.: 8951000046

Long anvil



MODEL	RC2405	RC2437Xi	RC2461	RC2471	RC2457Xi	RC2477Xi
Item number	8951000075	8951000068	8951000354	8951000355	8951000135	8951000046
Output drive size	1"	1"	1"	1"	1"	1"
Max. loosening torque	2,300 Nm	3,650 Nm	3,345 Nm	3,345 Nm	3,950 Nm	3,950 Nm
Max. torque in reverse	1,950 Nm	2,700 Nm	2,600 Nm	2,600 Nm	2,900 Nm	2,900 Nm
Working torque range (forward)	174–1,061 Nm	500–2,000 Nm	760–1,800 Nm	760–1,800 Nm	500–2,000 Nm	500–2,000 Nm
Free speed	5,760 rpm	6,000 rpm	3,900 rpm	4,600 rpm	5,900 rpm	5,900 rpm
Impact mechanism	DOUBLE DOG	DUOPACT	Closed Hammer mechanism	Closed Hammer mechanism	DUOPACT	DUOPACT
Air intake thread size	3/8"	1/2"	3/4"	3/4"	1/2"	1/2"
Noise level	96.8 dB(A)	100.8 dB(A)	103.3 dB(A)	103.3 dB(A)	106 dB(A)	106 dB(A)
Length	221 mm	280 mm	428 mm	530 mm	337 mm	490 mm
Weight	3.6 kg	7.2 kg	11.8 kg	12.8 kg	7.2 kg	8.1 kg

Recommended accessories
SOCKET SET
 See page 10



Torque wrench

Model	DMS200	DMS400	DMS1000
Item number	8951000093	8951000094	8951000095
Square size	1/2"	3/4"	1"
Capacity	40–200 Nm	150–750 Nm	200–1,000 Nm
Length	520 mm	1,060 mm	1,255 mm
Weight	2.02 kg	5.84 kg	6.84 kg

Reliable torque wrenches and, depending on the model, ideal for cars, motorcycles, small and medium-sized trucks, or truck and bus wheel assemblies and machine maintenance.

Torque adjustment with manual locking on the handle, with quick-change system for sockets. Scale in Nm, 4% accuracy in accordance with ISO 6789:2003 requirements.

ALL TORQUE WRENCHES UP TO 25,000 WORK CYCLES

Socket set 3/8"

13-Piece set, model RS3113

Item no.: 8951012354



Short hexagon sockets 3/8", 13-piece set in a plastic case: 7, 8, 9, 10, 11, 12, 13, 14, 15, 16, 17, 18, 19 mm

Socket set 1/2"

Long design, 3-piece set model RS413WP

Item no.: 8951012362

Wheel protection sockets 1/2", 3-piece in a plastic case: 17, 19, 21 mm



Socket set 1/2"

3-piece set, model RS413DTW

Item no.: 8951012353



Thin wall sockets 1/2", 3-piece set in a plastic case: 17, 19, 21 mm

Socket set 1/2"

14-piece set, model RS414

Item no.: 8951012356



Short hexagon sockets 1/2", 14-piece set in a plastic case: 10, 11, 12, 13, 14, 15, 16, 17, 18, 19, 21, 22, 26, 27 mm

Socket set 1/2"

14-piece set, model RS414D

Item no.: 8951012357



Long hexagon sockets 1/2", 14-piece set in a plastic case: 10, 11, 12, 13, 14, 15, 16, 17, 18, 19, 21, 22, 26, 27 mm

Socket set 3/4"

8-piece set, model RS618D

Item no.: 8951012359



Long hexagon sockets 3/4", 8-piece set in a plastic case: 26, 27, 29, 30, 32, 35, 36, 38 mm

Socket set 3/4"

8-piece set, model RS618

Item no.: 8951012358



Short hexagon sockets 3/4", 8-piece set in a plastic case: 26, 27, 29, 30, 32, 35, 36, 38 mm

Socket set 1"

4-piece set, model RS814D

Item no.: 8951012361



Long hexagon sockets 1", 4-piece set in a plastic case: 27, 32, 33, 36 mm

Socket set 1"

8-piece set, model RS818

Item no.: 8951012360



Short hexagon socket 1", 8-piece set in a plastic case: 27, 30, 32, 33, 35, 36, 38, 41mm

The ratchet product family from RODCRAFT!

Ideal for all applications that require high speeds for fast work and high torque.

- **Planetary gearing with 3 bevel gears**
- **Head closed for higher manually applied torque**
- **Heavy-duty ball-lock drive**
- **Exhaust air adjustable by 360°, 4 power levels adjustable by ring**

Pneumatic ratchet 1/4"

Model RC3068

Item no.: 8951000369

Output drive size:	1/4"
Housing:	Composite
Max. torque:	45 Nm
Speed:	280 min ⁻¹
Weight:	0.67 kg
Length:	212 mm



Pneumatic ratchet 3/8"

Model RC3268

Item no.: 8951000370

Output drive size:	3/8"
Housing:	Composite
Max. torque:	50 Nm
Speed:	280 min ⁻¹
Weight:	0.68 kg
Length:	212 mm



Pneumatic ratchet 3/8"

Model RC3278

Item no.: 8951000371

Output drive size:	3/8"
Housing:	Composite
Max. loosening torque:	100 Nm
Speed:	190 min ⁻¹
Weight:	1.22 kg
Length:	260 mm



Pneumatic ratchet 1/2"

Model RC3678

Item no.: 8951000372

Output drive size:	1/2"
Housing:	Composite
Max. torque:	100 Nm
Speed:	190 min ⁻¹
Weight:	1.25 kg
Length:	260 mm



Ratchet wrench 1/2"

Model RC3700

Item no.: 8951078074

Output drive size:	1/2"
max. loosening torque:	250 Nm
Speed:	320 min ⁻¹
Weight:	1.6 kg
Length:	312 mm

1/2" ratchet with 130 Nm motor power, which can still be used by hand like a wrench up to 250 Nm.



Ratchet wrench 1/4"

Model RC3001

Item no.: 8951078022

Output drive size:	1/4"
max. torque:	30 Nm
Speed:	270 min ⁻¹
Weight:	0.44 kg
Length:	140 mm

Very short and powerful 1/4" mini-ratchet for use in confined areas
Anti-slip coated handle





The new **RODflex** series

NEW

Flex Head Ratchet 3/8"
Model RC3288

Item no.:8951000460

Free Speed	169 min ⁻¹
Length	272 mm
Max. Torque	80 Nm
Working Torque	53 Nm
Square Drive	3/8"
Weight	1.42 kg

Flex Head Ratchet 1/2"
Model RC3688

Item no.: 8951000461

Free Speed	165 min ⁻¹
Length	272 mm
Max. Torque	90 Nm
Working Torque	60 Nm
Square Drive	1/2"
Weight	1.43 kg

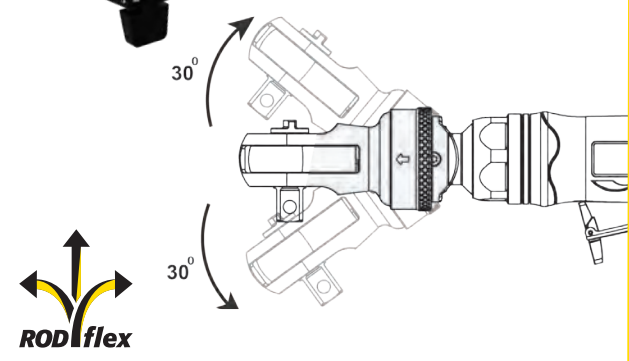

The Flex Head Ratchet is designed to fit in hard-to-reach spaces thanks to its head with 30° rotation up or down. The tool has a safety lever, aluminum alloy housing and TPR grip for a perfect, comfortable and safe usage. This unique design is not only ergonomic, but also fast and powerful with high speed of 165rpm and Max Torque of 90Nm.



Flexible Head Cut-Off Tool
Model RC7199

Item no.:8951000447

RC7199 + Cutting discs

Item no.:8951000457

Spindle Thread	3/8"
Disc	3"
Power	440 w
Free Speed	16000
Weight	1.3 kg
Length	248 mm



The Flexible Cut Off Tool is designed to fit in hard-to-reach spaces thanks to its head with 25° rotation up or down. The tool has a quick lock ring design for fast flex head position change, a grip & guard made from recycled materials. With outstanding safety with the spark control on the top side of the housing, the RC7199 is an ergonomic, safe and flexible tool.



The MINI SERIES from RODCRAFT

The new product family includes eight tools that cover classic work in confined spaces in vehicle service and industrial maintenance. With a very small design, low weight and high performance, the ergonomic tools have been developed with the usual high Rodcraft quality for professional and long-term use.



MINI
Die grinder
Model RC7001

Item no.: 8951000428

For straight access to the workpiece

- Only 116 mm long
- Up to 25,000 rpm
- With 6 mm collet



MINI
Die grinder
Model RC7102

Item no.: 8951000429

Grinding head 90° angled for hard-to-reach places

- Only 126 mm long
- Up to 18,000 rpm
- With 6 mm collet



MINI
Angle grinder
Model RC7103

Item no.: 8951000430

Compact design for cutting and grinding in confined spaces

- Only 129 mm long
- Up to 18,000 rpm
- For 50 to 59 mm cutting discs (2"–2.5")



MINI
Disc sander
Model RC7601

Item no.: 8951000431

Compact design for grinding in confined spaces

- Only 126 mm long
- Up to 18,000 rpm
- For 50 mm quick-change abrasive pads (Roloc/swivel mount)



MINI
Polisher
Model RC7602

Item no.: 8951000432

Compact design for use in confined spaces

- Only 152 mm long
- Perfect polishing speed with up to 4,500 rpm
- For 50 mm quick-change polishing pads (Velcro/Klett)



MINI
3/8"
Ratchet wrench
Model RC3201

Item no.: 8951000433

For use in confined spaces

- Only 135 mm long
- 3/8" output drive size
- Fast screwing with up to 300 rpm
- 50 Nm torque



MINI
Multifunction
ratchet wrench
Model RC3202

Item no.: 8951000434

With interchangeable square and hexagonal inserts

- Only 160 mm long
- Incl. 5 interchangeable inserts (3/8", 1/4" Bit holder, hexagon socket: 10 mm, 12 mm, 13 mm and 17 mm)
- Rubber-coated ratchet head to protect sensitive parts
- Fast screwing with up to 400 rpm
- 50 Nm torque



MINI
Ratchet
wrench
Model RC3203

Item no.: 8951000435

Compact & powerful 3/8" ratchet wrench for confined spaces

- Only 158 mm long
- 3/8" output drive size with 1/4" bit holder
- High level of occupational safety thanks to the reaction-free high-performance pin hammer mechanism
- Fast screwing with up to 600 rpm
- 50 Nm torque

**Drill in a pistol design
model RC4108**

Item no.: 8951000422



- With high-quality quick-change chuck from Jacobs®
- Cold-insulating and lightweight composite housing
- Sensitive trigger for more control when drilling
- Right / left switch directly next to the release button
- Good weight balance and low weight (1.1 kg)

**Drill in a pistol design
Model RC4560**

Item no.: 8951000423



- With high-quality quick-change chuck from Jacobs®
- The additional handle is lightweight and individually adjustable by 360 degrees (model with 13 mm and 800 rpm)
- Sensitive trigger for more control when drilling
- Right / left switch directly next to the release button
- Good weight balance and low weight (1.3 kg)

**Angle drill
Model RC4660**

Item no.: 8951000424



- With high-quality quick-change chuck from Jacobs®
- Compact, low profile for easy access in cramped locations
- Safety trigger for controlled work without accidental start-up
- Integrated ring for changing from right to left rotation
- Good weight balance and low weight of only 1.1 kg
- Cold-insulating and lightweight composite housing

**Straight drill
Model RC4610**

Item no.: 8951000425



- With high-quality quick-change chuck from Jacobs®
- Compact, low profile for easy access in cramped locations
- Safety trigger for controlled work without accidental start-up
- Good weight balance and low weight of only 1 kg
- Cold-insulating and lightweight composite housing

With the four pneumatic drills and the two pneumatic screwdrivers from RODCRAFT workshops for vehicle servicing or companies in the field of industrial repair and assembly are fully equipped - flexible, ergonomic and with a long service life.

CHUCK



Item no.: 8951011458

Self-tightening 10 mm compound chuck with non-slip coating, "RÖHM®" quality.

Item no.: 8951011459

Self-tightening 13 mm composite chuck with non-slip coating, "RÖHM®" quality.



Item no.: 8951011451

10 mm key chuck with non-slip coating, "RÖHM®" quality.

Item no.: 8951011452

13 mm key chuck with non-slip coating, "RÖHM®" quality.

KEY

Item no.: 8951011453



Screwdriver in a pistol design

Model RC4710

Item no.: 8951000426



- Quick-change chuck, 1/4" hexagon socket for quick tool changes
- Fast and exact torque adjustment, 2 – 6 Nm, sensitive trigger and progressive valve for controlled screwing
- Cold-insulating and lightweight composite housing
- Slim housing for perfect handling, low weight of only 1.1 kg

Rod screwdriver

Model RC4770

Item no.: 8951000427



- Quick-change chuck, 1/4" hexagon socket for quick tool changes, speedy and precise torque adjustment, 2 – 6 Nm
- Integrated ring for right/left rotation, safety trigger for controlled work without accidental start-up
- Cold-insulating and lightweight composite housing (only 1.1 kg), optional balancer bracket

Model	RC4108	RC4560	RC4660	RC4610	RC4710	RC4770
Item number	8951000422	8951000423	8951000424	8951000425	8951000426	8951000427
Power	400 W	400 W	300 W	500 W	400 W	300 W
Speed	2,000 rpm.	800 rpm.	1400 rpm.	3,000 rpm	2000 rpm.	2,000 rpm.
Torque	6.5 Nm.	13.5 Nm.	6.5 Nm.	5.5 Nm.	2–6 Nm.	2–6 Nm.
Free speed Air consumption	1.88 l/s	1.88 l/s	1.54 l/s	1.78 l/s	1.84 l/s	1.63 l/s
Shape	Pistol	Pistol	Angled	Straight	Pistol	Straight
Reversible	Yes	Yes	Yes	No	Yes	Yes
Weight	1.05 kg	1.33 kg	1.06 kg	1.03 kg	1.05 kg	1.06 kg
Chuck capacity / Output drive	10 mm	13 mm	10 mm	10 mm	1/4" bit drive	1/4" bit drive
Noise level	90 dB(A)	89 dB(A)	85.2 dB(A)	84 dB(A)	90.3 dB(A)	85.0 dB(A)
Vibration	2.1 m/s ²	1.5 m/s ²	2.73 m/s ²	2.87 m/s ²	1.2 m/s ²	0.61 m/s ²
Dimensions L x W x H [mm]	195 x 40 x 155	230 x 43 x 155	207 x 43 x 120	245 x 72 x 50	212 x 42 x 155	258 x 56 x 42



Chisel hammer Model RC5100

Item no.: 8951071022

Pneumatic hammer with
11 mm hexagonal shaft
Bare tool, chisel not included



Power: 6 joules
Bore: 19 mm
Height: 160 mm
Width: 39 mm
Length: 200 mm
Stroke: 60 mm
Shaft: 11 mm

Chisel hammer set Model RC5120

Item no.: 8951171013



Complete set for metalworking and
processing metal sheets.
In a toolbox with:

pneumatic hammer RC5100 /
holding spring RC70
Rivet removal chisel RC22S
Spot-weld separation chisel RC19S
Double-edged sheet metal chisel RC60S
Flat chisel RC20S
Curve separation chisel RC18S

Chisel hammer set Model RC5150

Item no.: 8951171023



Complete set for processing
concrete and stone.
In a toolbox with:

pneumatic hammer RC5100 /
Solid bracket RC76-1
Sharp chisel 240 mm long SS10
Flat chisel 240 x 20 mm SS20
Flat chisel 240 x 30 mm SS30
Flat chisel 240 x 40 mm SS40
Hollow joint chisel 240 mm SS50

Chisel hammer Model RC5176

Item no.: 8951171043

- Ready-to-use hammer set
for concrete and stone processing
- Hexagonal shaft allows directional chisel
guidance
- Included in set:
- 8951071042 - Hammer RC5175
- 8951011958 - Chisel spring retainer D34
- 8951011932 - Chisel 11mm hex shank-
210mm Pointed SS10
- 8951011934 - Chisel 11mm hex shank-
210mm SS20
- 8951011962 - Retainer chisel steel RC76-1



Chisel hammer Model RC5185/vibration damped

Item no.: 8951000152

- Highly efficient:
9 joules / 3,000 impacts/min
- Low vibrations:
Pistons on air cushions
- High durability and lightweight
- Simple to operate Quick-change chuck
- Curved, ergonomic handle with cold-
insulating rubber area for a perfect grip



Chisel hammer Model RC5195/vibration damped

Item no.: 8951000154

- Highly efficient:
12 joules / 2,100 impacts/min
- Low vibrations:
Pistons on air cushions
- High durability and lightweight
- Simple to operate Quick-change chuck
- Curved ergonomic handle with TPR inserts
on the back for more comfort and for
decoupling



Chisel hammer 12 mm, model RC5305

Item no.: 8951071065

Power: 6 joules
Bore: 20 mm
Stroke: 50 mm
Shaft: 12 mm

Powerful for heavy-duty applications. Small,
straight hammer for metal or stone with 12 mm
hexagonal holder, chisel holder made of steel
RC76-3



Chisel hammer SET 12 mm, model RC5310

Item no.: 8951171053

Contains RC5305 and 4 chisels:



- Sharp chisel 210 mm long RC51S
- Flat chisel 210x20 mm RC52S
- Flat chisel 210x30 mm RC53S
- Flat chisel 210x40 mm RC54S

For working on concrete and stone in a
toolbox with pneumatic RC5305, solid holder
RC76-3.

Chisel hammer 14.7 mm, model RC5400

Item no.: 8951071076

Power: 22 joules
Bore: 29 mm
Stroke: 76 mm
Shaft: 14.7 mm

Chisel hammer for the most demanding
work. Powerful, large hammer with 14.7 mm
hexagonal shaft for heavy-duty applications.
Chisel hammer made from steel



Universal chisel Model RC92

Item no.: 8951011953



Mount: 14.7 mm hexagonal
Length: 190 mm
Width: 30 mm

Sharp chisel Model RC93

Item no.: 8951011954



Mount: 14.7 mm hexagonal
Length: 185 mm

Flat chisel

Model	SS20	SS30	SS40
Width	20 mm	30 mm	40 mm
Item number	8951011934	8951011936	8951011938
Length	210 mm	205 mm	210 mm
Mount	11 mm hexagonal	11 mm hexagonal	11 mm hexagonal

Needle scaler

Model RC5610

Item no.: 8951076001

- 2 in 1 tool – Needle scaler / weld flux chipping hammer
- For scaling and paint removal with one tool.
- Scraper for removing larger sheets of paint, rust or weld flux.
- For thick sheet metal or stone / concrete (not suitable for thin sheet metal).



Needle scaler

Model RC5615

Item no.: 8951076002

- Small device for confined spaces.
- For removing rust and other deposits from rims or frame parts.
- For thick sheet metal or stone / concrete (not suitable for thin sheet metal).



Needle scaler

Model RC5620

Item no.: 8951076003

- Heavy pistol-shaped tool
- With 4 mm needles for coarse rust removal
- With 28 x 3 mm needles for moderately heavy work on large areas
- Only for use on thick sheet metal or stone / concrete (not suitable for thin sheet metal)



Needle scaler

Model RC5625

Item no.: 8951076004

- Lightweight pistol-shaped tool
- With 3 mm needles for moderately severe rust removal
- With 29 x 2 mm needles for carving out fine details or working on larger surfaces
- Only for use on thick sheet metal or stone / concrete (not suitable for thin sheet metal)



Needle set for RC5625



19 X 3 mm

29 X 2 mm

Item no.: 8940159860 Item no.: 8951011504

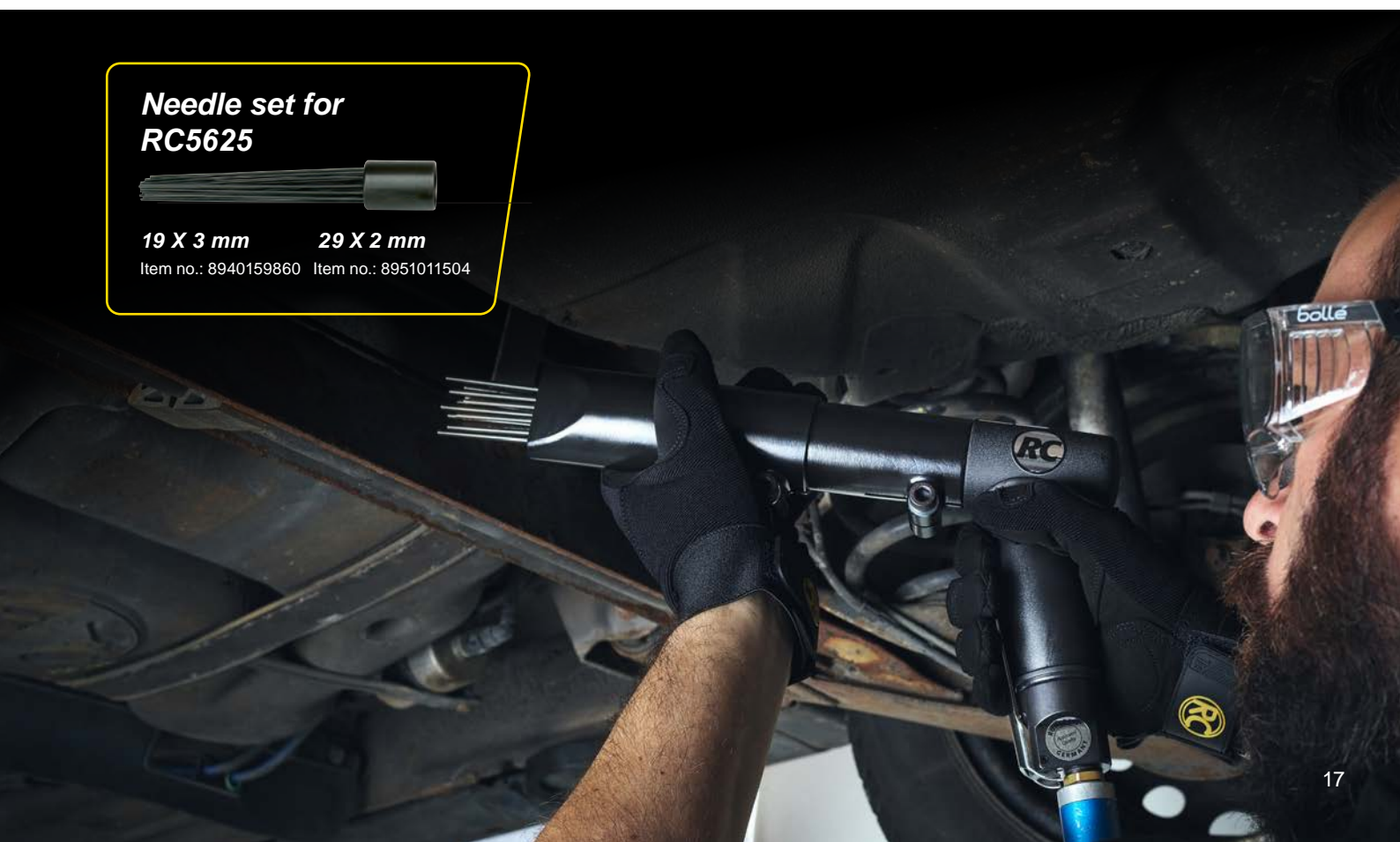

The RC7155/7156 belt sander range is perfect for body shop and general repair jobs

- Quick replacement of the sanding belts (10 mm and 20 mm) thanks to the quick-release device
- Efficient working with a speed of 18,000 rpm
- Adjustable sanding arm for better reachability
- Small and manageable tool for confined spaces
- Exhaust air routing to the rear for greater occupational safety

Belt sander Model RC7155

Item no.: 8951072041

Power: 300 W
 Speed: 18,000 rpm
 Length: 285 mm
 Weight: 0.8 kg
 Sanding belt (L x W): 330 x 10 mm



Belt sander Model RC7156

Item no.: 8951072051

Power: 370 W
 Speed: 17,000 rpm
 Length: 353 mm
 Weight: 1.15 kg
 Sanding belt (L x W): 520 x 20 mm



Sanding belts

Grain size	Item no.	Dimensions	Quantity	Grain size	Item no.	Dimensions	Quantity
40	8951011604	10 x 330 mm	10	80	8951011580	20 x 520 mm	10
80	8951011570			120	8951011581		
120	8951011577			180	8951011582		
180	8951011578			240	8951011583		
240	8951011579						



Pistol sander Model RC7150

Item no.: 8951072021

The RC7150 disc sander is the perfect tool for automotive and body shops to efficiently sand and smooth surfaces



- High-speed disc sander with 18,000 rpm
- Integrated air regulator with throttle valve for a finely adjustable speed
- Robust, energy-efficient 500 watt motor

Mini pistol sander Model RC7681K

Item no.: 8951000019

The RC7681K mini disc sander is ideal for body shop applications



- Efficient working with a maximum speed of up to 15,000 rpm
- Lightweight composite body weighing only 0.4 kg and rubberized grip for ergonomic handling
- Adjustable power control with thumb button for one-handed operation



Orbital sander**One-hand/two-hand orbital sander**

Model	Item number	Orbit	Speed	Padø	Weight	Air consumption	Air intake thread size
RC7702V6	8951000021	2.5 mm	10,000 rpm	150 mm	0.83 kg	7.5 l/s	1/4" BSP
RC7705V6	8951000020	5 mm	10,000 rpm	150 mm	0.85 kg	7.5 l/s	1/4" BSP
RC7710V6	8951000070	10 mm	10,000 rpm	150 mm	0.95 kg	7.5 l/s	1/4" BSP
RC7710V6-2H	8951000082	10 mm	10,000 rpm	150 mm	1.1 kg	7.5 l/s	1/4" BSP

Particularly powerful motor with 285 watts for vertical and horizontal applications

Manageable and lightweight tool with high operating comfort thanks to the ergonomic palm shape with soft grip for perfect control



Available as a one-handed version model RC7705V6 and two-handed version with additional handle RC7705V6-2H

The lightweight and powerful RC7705V6/RC7705V6-2H series orbital sanders are perfect for final sanding, finishing and pre-polishing

**Replacement sanding disc**

Item no.: 8955000012



For models RC7710V6 and RC7705V6-2H.

**Orbital sander
Model RC7661V**

Item no.: 8951072231

The RC7661V is an orbital sander for use in body and paint shops

Orbital sander with 2.5 mm orbit for final sanding, finishing and pre-polishing. Pad diameter 75 mm.

**Orbital sander /
pad diameter
50 mm / 75 mm
Model RC7682**

Item no.: 8951000005

The RC7682/7682K range of mini pistol-shaped orbital sanders are the ideal tools for surface preparation and spot repair

- Efficient working with a 5 mm orbit and a speed of 15,000 rpm
- Lightweight composite housing only 124 mm in length and weighing only 0.5 kg and with a rubberized grip for ergonomic handling

**Orbital sander
200 mm
Model RC7691V**

Item no.: 8951072212

The RC7691V orbital sander is the ideal tool in body shops and paint shops

Particularly powerful motor with 210 watts for aggressive and efficient sanding on large areas

**Pneumatic orbital sander
as a set, model RC7682K**

Item no.: 8951000018

Small powerful sander for quick completion of small areas of sanding / smart repair

- Speed regulation in the grip area
- Incl. supporting disc ø50+75 mm
- Incl. 10 sanding discs each with a grain size of 600, 320, 180, in ø50+70 mm

Lift: 5 mm
Orbit: 5 mm
Speed: 15,000 rpm
Weight: 0.53 kg
Noise level: 79.6 dB(A)
Vibration: 8.9 m/s²
Air connection: 1/4"



Die grinder

The RC7028/RC7048/RC7128 ranges of sanders are perfect for automotive, body shops and general maintenance shops



Model	RC7028	RC7048	RC7128
Item number	8951000275	8951000276	8951000277
Power	400 W	400 W	400 W
Speed	27,000 rpm	27,000 rpm	23,000 rpm
Length	191 mm	250 mm	169 mm

Mini die grinder

Model RC7051

Item no.: 8951000165



- High speed of 60,000 rpm for efficient working
- Collet for 3 mm sanders and milling cutters
- Sound absorbing hose included for a low noise level of 71 dBa

Die grinder Model RC7009

Item no.: 8951000274

The RC7009 rod sander is perfect for general maintenance jobs and for high-speed sanding



Die grinder Model RC7058

Item no.: 8951000278

The RC7058 is the powerful and ergonomic sander for general maintenance and everyday use



Engraving pen Model RC5030

Item no.: 8951071010



The Rodcraft RC5030 pneumatic engraver is the ideal tool for any workshop to permanently mark or number parts

Very robust and powerful 300 watt motor with 30,000 rpm for continuous use.

Efficient work with an power of 700 watts and up to 23,500 rpm.

Pneumatic die grinder 400 W, 2,800 rpm Model RC7068

Item no.: 8951000329



The RC7068 is the high-torque and ergonomic die grinder for maintenance and everyday use

Efficient work with an power of 400 watts and up to 2,800 rpm.

WWW.RODCRAFT.COM

You will also find our complete range online:

- Online catalog pneumatic tools
- Online catalog repair shop equipment
- Rodcraft accessories
- Technical documentation
- Rodcraft sales and dealer contacts

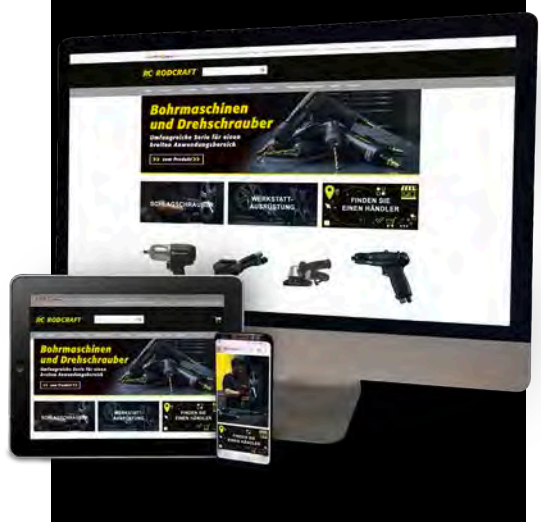

Tire buffer

Model RC7088

Item no.: 8951000330

Popular carcass sander with high torque and keyless chuck.

- Powerful, low-revving planetary gearing.
- With quick-change mounts with thread adapter 3/8"-24.
- Free speed: 2,800 rpm
- Power: 400 watts
- Air inlet: 1/4"
- Weight: 1 kg



Disc 3/8" for tire buffer

Item no.: 8940175873



Die grinder

Model RC7038

Item no.: 8951000328

- Mount: 5/16"
- Speed: 2,800 rpm
- Power: 400 watts
- Weight: 1.0 kg



Erasing disc

Item no.: 8951011677

Optimal for removing foils and stickers as well as adhesive residues from balancing weights on rims

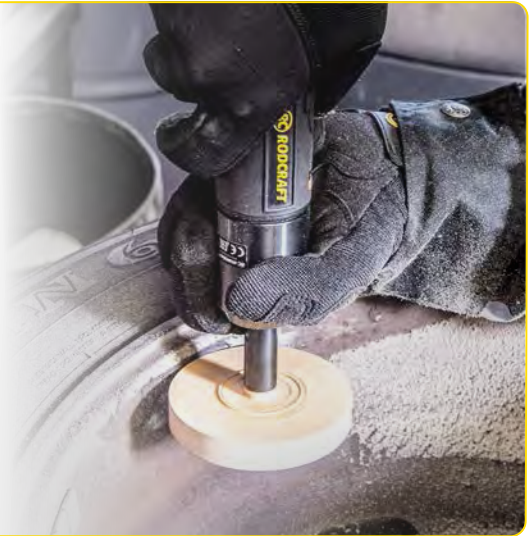

NEW

RC7095/ RC7095K MBX Multi Sander
Work efficiently on all kinds of surface preparation

The Rodcraft RC7095 MBX Multi Sander has been developed to better serve customers working in general mechanics maintenance or body shop applications.

This Multi Sander tool is a complete solution for all kinds of surface preparation such as rust removal, corrosion, paint, plastic film, labels, underseal, sealing compound and paint stripping on any type of supports.

- Detachable dust extraction system
- 180° Easily adjustable side handle
- 1.4 Kg with accessories
- Arc Guard for operator's safety
- Speed regulator at top of housing
- Composite housing
- Recyclable materials on guard and vacuum



Technical data

Model	RC7095	RC7095K
Item number	8951000450	8951000462
Power	346 W	346 W
Speed	3,893 rpm.	3,893 rpm.
Length	332 mm	332 mm
Width	84 mm	84 mm
Height	260 mm	260 mm
Net weight	1.4 kg	1.4 kg
Sound pressure dB(A)	83.2 dB(A)	83.2 dB(A)
Vibration	2.2 m/s ²	2.2 m/s ²
Air inlet thread size (")	1/4"	1/4"
Free speed air consumption	1.5 l/s	1.5 l/s
EAN	4030178835292	4030178835339



RC7095K
Kit including accessories

Accessories



HUB system
Item no.: 8955000129
HUB width 23 mm



HUB system
Item no.: 8955000130
HUB width 11 mm



Wire wheel (fine)
Item no.: 8955000134
wheel width 11 mm
Item no.: 8958001557
wheel width 23 mm



Wire wheel (medium)
Item no.: 8955000133
wheel width 11 mm
Item no.: 8958001558
wheel width 23 mm



Wire wheel (coarse)
Item no.: 8955000131
wheel width 23 mm
Item no.: 8955000132
wheel width 11 mm



4" Rubber eraser wheel
Item no.: 8955000135
wheel width 30 mm



4" Stripping wheel
Item no.: 8958001556



RCA1000, Motor oil 1L
Item no.: 8955000117



Polisher
Model RC7683

Item no.: 8951000004

The RC7683 range of mini polishers is perfect for body shop, body repair and paint shop jobs.



Polisher in a set,
model RC7683K

Item no.: 8951000017



Small powerful polisher ideal for smart repairs

- Speed regulation in the grip area
- Incl. supporting disc ø 75 mm
- Incl. 1 white and 1 yellow polishing foam and and 1 polishing pad

Angle polisher
Model RC7130

Item no.: 8951072004



- Powerful motor with 500 watts and up to 2,500 rpm for high productivity
- Hardened and ground spiral bevel gears
- Large 170 mm angle polisher with extra flat head and 5/8" spindle including lambswool polishing pad

Angle grinder
Model RC7190

Item no.: 8951075101

The small RC7190 direct-drive cutting sander with its straight design is ideal for cutting in confined spaces



- Adjustable speed up to 20,000 rpm
- For discs up to 75 mm
- High level of safety thanks to an easily adjustable protective hood made of steel and a safety release

Cutting discs for
model RC7190

Item no.: CA155312



Set of 5 discs
Dimensions: 75 x 2 x 10 mm

Angle grinder,
incl. 5 cutting discs
Model RC7170

Item no.: 8951000144



- Ideal for cutting composite materials, metal, screws.
- 100 mm-long shaft
- compact housing
- incl. 5 Norton® cutting discs

Angle grinder (125 mm)
Model RC7173

Item no.: 8951000212

High power with 700 watts and a speed of 12,000 rpm thanks to the regulated motor that maintains the optimum speed at high working torque.

- maintenance interval 1,000 hours
- High-quality spiral bevel gears and high-performance motor



Angle grinder
Model RC7166

Item no.: 8951075051

- Powerful with 750 watts and 10,000 rpm
 - For 115 mm and 125 mm cutting and sanding discs.
- With M14 spindle thread and therefore compatible with power tool accessories.



Saw
Model RC6050

Item no.: 8951079001



- With blade change from the outside and exhaust air to the rear
- Handy and fast, with an insulated handle
- Lift: 10 mm
- Speed: 500 rpm

Saw blades

- Set of 5 blades
- Length: 93 mm
- Suitable for models RC6050 and RC6067



Saw
Model RC6051

Item no.: 8951179000



- Cold-insulated handle
- 10 mm saw blade stroke
- Perfect for dimensionally accurate sawing of body parts, spars and profiles

Saw
Model RC6067

Item no.: 8951079011



- Powerful pneumatic air saw with composite handle, suitable for cutting spars and multi-layer sheet metal parts
- With long saw blades, profiles and silencer pipes can be processed in one cut
- 10,000 strokes/min
- Can be converted to a pneumatic air file using an adapter (optional accessory)
- Handy and fast, with an insulated handle

Saw
Model RC6070

Item no.: 8951000463

NEW



- A gear driven saw that is reshaping the landscape of maintenance
- Keyless blade changing mechanism and protective guards for perfect grip
- Max speed of 4,600 strokes/min., minimum speed of 4,200 strokes/min.
- Alternating speeds to choose between ultimate efficiency or prolonged blade life

Sheet metal nibbler
Model RC6100

Item no.: 8951076008



- Ideal for cutting car body and aluminum sheets
- Cutting speed: 2.6 m/min
- Max. sheet thickness: 1 mm
- Cutting width: 4 mm
- Weight: 0.95 kg
- Noise level: 91.6 dB(A)
- Vibration: 8.55 m/s²
- Air connection 1/4"

Punch machine
Model RC6301

Item no.: 8951076011



The RC6301 punch and stripping pliers is the ideal combination tool for welding preparation in bodywork and sheet metal processing

- For cutting and punching up to a maximum material thickness of 1.2 mm
- Punches 5 mm holes for weld preparation, also suitable for spot weld preparation

Pneumatic rivets guns and rivet nut setting tool



Riveter Model RC6700

Item no.: 8951074001

Rivet gun for blind rivets made from soft metals such as copper, aluminum 2.4–5.0 mm with collection container for pulled off rivet mandrels.

Setting force: 8.8 kN



Riveter Model RC6738

Item no.: 8951000408

Rivet gun for blind rivets made from high-strength materials such as steel and stainless steel 3.0 - 5.0 mm with collection container for pulled off rivet mandrels and suction of blind rivets, ideal for comfortable vertical work.

Setting force: 12.6 kN



Riveter Model RC6748

Item no.: 8951000409

Rivet gun for blind rivets made from high-strength materials such as steel and stainless steel 4.8 - 6.4 mm, as well as special rivets (e.g.: BULB-TITE®) up to 7.8 mm. With collection container for pulled off rivet mandrels and suction of blind rivets, ideal for comfortable vertical work.

Setting force: 21.0 kN



Blind rivet nut setting tool Model RC6758

Item no.: 8951000410

Blind rivet nut setting tool for rivet nuts M3–M12 made from all materials. Fast handling of the rivet nut using automatic twisting and unscrewing. Precise adjustment of the setting stroke.

Setting force: 24.0 kN



Model		RC6700	RC6738	RC6748	RC6758
Standard blind rivets with open / closed end	Aluminum	2.4–5.0 mm	3.0–5.0 mm	4.8–6.4 mm	–
	Copper	2.4–5.0 mm	3.0–5.0 mm	4.8–6.4 mm	–
	Steel	–	3.0–5.0 mm	4.8–6.4 mm	–
	Stainless steel	–	3.0–5.0 mm	4.8–6.4 mm	–
Structure blind rivets	BULB-TITE®	–	–	5.2–7.8 mm	–
	Monobolt®, Magnalok®, Interlok®	–	–	4.8–6.4 mm	–
	Hemlok®	–	–	6.4 mm	–
Blind rivet nuts	Single-grip	–	–	4.8–5.0 mm	–
	all materials	–	–	–	M3–M12
Additional tool function	Suction of rivet mandrels	yes	yes	yes	–
	Vacuum function for the suction of blind rivets	–	yes	yes	–

Spot weld drill Model RC6453

Item no.: 8951076013



Spot weld drill for bodywork and sheet metal processing professionals for the precise and convenient removal of spot welds

- The milling cutter is automatically pressed on to the sheet metal when the tool is started up and ensures precise removal of the spot weld
- Milling depth adjustable by 50 microne steps

Drill for RC6453

Item no.: 8951011524



Double suction cup set Model STS71K

Item no.: 8951011087



Two double suction cups for transporting, installing and removing windscreens and other glass panes. Comes with a strap that holds the windshield in place while the adhesive dries. (max. 80 kg)

"UNICUTTER" – Windscreen removal tool Model RC6605RE

Item no.: 8951074005



Universal cutting, scraping and sawing device for removing car windscreens.

Oscillation cutter /glass removal tool Model RC6606RE

Item no.: 8951174000

Perfect for any car and body shop that needs to quickly and professionally replace vehicle windows

Glass removal blade GR SET

Item no.: 8956001327
Set comprises U-shaped and straight blades. (7 blades)



Windscreen removal tool Model RC6610

Item no.: 8951074000



Exhaust air at the rear end of the tool for high occupational safety

Glass removal blade

Blades U-shape



Model	U27	U37	U64	U95
Item number	8956001320	8956001328	8956001324	8956001325
Blade length	24 mm	36 mm	63 mm	90 mm
PI	2 blades	2 blades	2 blades	2 blades

Blades straight



Model	G36	G58	G95
Item number	8956001323	8956001322	8956001321
Blade length	35 mm	53.5	90 mm
PI	2 blades	2 blades	2 blades

Tyre filler calibrated with torque plug nipple, model RF02G

Item no.: 8951011019

Professional tire inflator with 500 mm hose and torque plug nipple. Calibrated pressure display 0 - 10 bar. Lightweight design with analog 60 mm pressure gage and shock protection. Push button to lower tire pressure and lever to inflate



Tyre filler Calibrated, model RFP04G

Item no.: 8951012306

Calibrated high-flow tire inflator, EEC recognized and certified in accordance with instruction no. 71/316.

Easy to use with a lever to inflate and a button to deflate.



Blow and suction gun Model RC8116

Item no.: 8951070004



Robust metal housing with 4 different nozzles, suction hose and dust bag made of fabric. Ideal for residue-free suctioning when repairing tires.

Air pressure: 6 bar
Air connection: 1/4"

Paint gun Model RC8102-14

Item no.: 8951070002



0.6 l plastic paint cup, equipped with 1.4 mm nozzle

- Beam shape adjustable (round or narrow, rotatable nozzle head)
- Finely adjustable operating lever
- Air volume adjustment
- Quantity limitation

Grease gun, filled Model RC8150F

Item no.: 8951012205



Particularly suitable for lubricating angle gears and impact mechanisms.

Grease gun filled with 2 cartridges model RC8150

Item no.: 8951012204



Lubrication gun/grease gun RC8150, incl. 2 cartridges (filled), 168 x 34 mm

5 replacement cartridges model RC8150K

Item no.: 8951012206

Refill cartridges (5 cartridges for RC8150)



Cleaning gun Model RC8011

Item no.: 8951070040



The RC8011 pneumatic cleaning gun is perfect for workshops that deal with underbody protection.

Cartridge gun Model RC8000

Item no.: 8951070000



With steel cylinder for cartridges up to 310 ml and a size up to 220x50mm.

Grease gun Model RC8132

Item no.: 8951000059



The RC8132/RC8141 range of grease guns should be part of every workshop for general maintenance and lubrication work

Grease gun Model RC8141

Item no.: 8951070090



- For cartridges 215 x 50 mm (400 ml), bags or direct filling via a lubricant tank
- Progressive trigger for even distribution of lubricant (continuous or point by point)

Cleaning gun Model RC8035

Item no.: 8951070050



Spray gun for multiple applications:
Underseal spray gun for 1 l cans with screw thread
Cavity sealing gun with nozzle tube for 1 l cans
Cleaning spray gun with 1 l tank and nozzle tube with adjustable spray nozzle
Disinfectant gun for air conditioning and air ducts with tanks

Sandblaster Model RC8112

Item no.: 8951070003



Portable blasting material container (10 l) with a long (5 m) blasting material suction hose for connection to the container and gun.

Suitable for structural steel, wheel rim repairs, bodywork, car, commercial vehicle, truck repairs, mechanical engineering and industry.

Air blow gun RC8240S

Item no.: 8955000009



RC8241S

Item no.: 8955000011



RC8241

Item no.: 8955000010



RC8240

Item no.: 8955000026



The safety nozzles prevent paint scratches and are significantly quieter than standard nozzles. Large airflow even at low pressure - twice as powerful as a standard air gun. Gentle start-up thanks to an easily adjustable valve. Stable air inlet with brass internal thread.

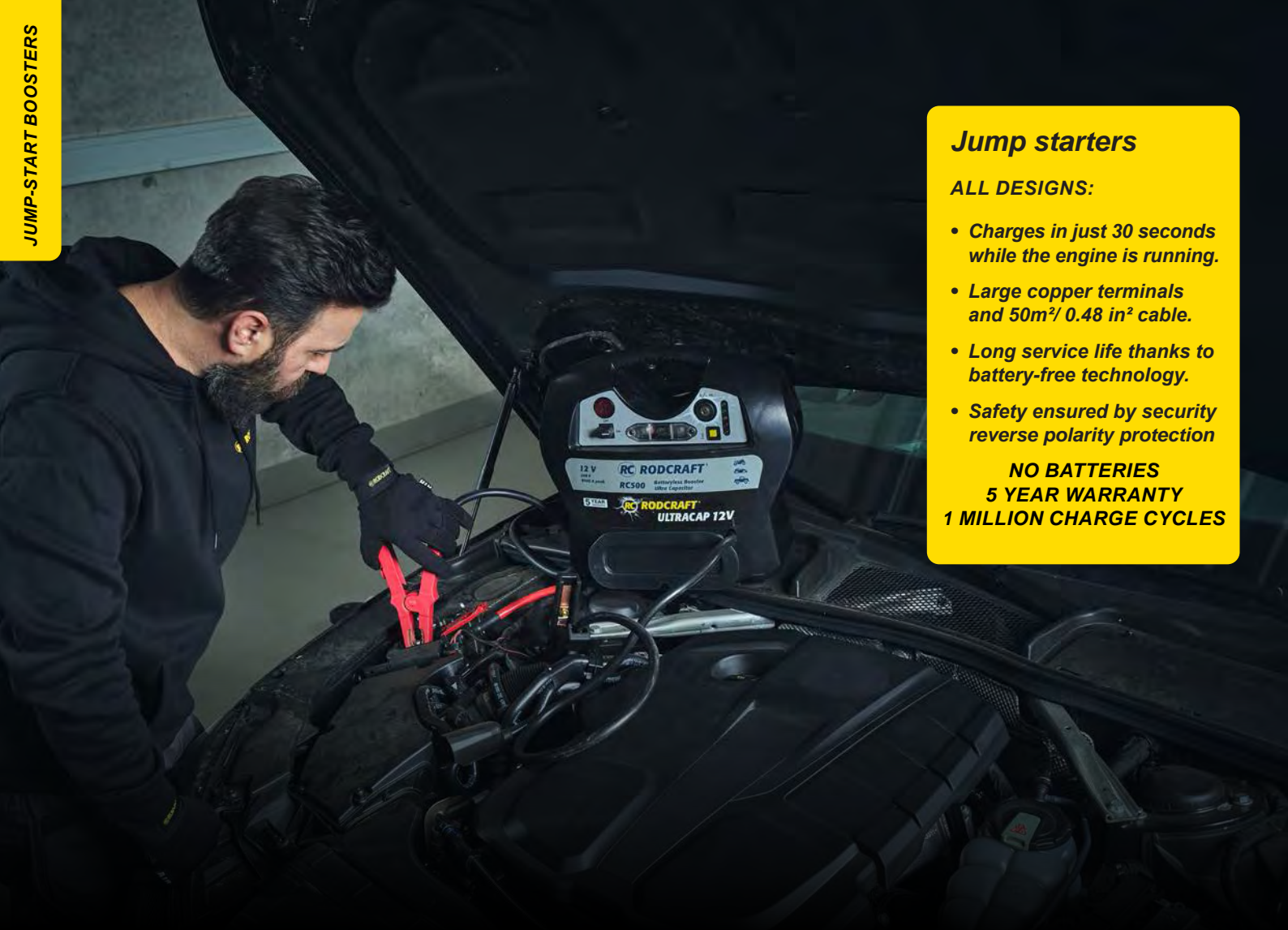

Jump starters

ALL DESIGNS:

- Charges in just 30 seconds while the engine is running.
- Large copper terminals and 50m²/ 0.48 in² cable.
- Long service life thanks to battery-free technology.
- Safety ensured by security reverse polarity protection

**NO BATTERIES
5 YEAR WARRANTY
1 MILLION CHARGE CYCLES**

Capacitor booster, 12/24V Model RC600

Item no.: 8951000362

High-performance, ultra-capacitor with 16,000 A at 12V and 8,000 A at 24V power. Suitable for all engines with 12V and 24V batteries.

Capacitor booster, 12V Model RC500

Item no.: 8956001301

High performance, 500F ultra-capacitor with 9,000 A power, suitable for all motors with a 12V battery.



Creeper foldable, model RSF01

Item no.: 8951089021

2-in-1: Assembly roller board and sliding seat for various working heights.

Comfortably padded, easy to clean surfaces.



- Load-bearing capacity 90 kg
- Height: 480 mm
- Width: 450 mm



Creeper Model RSF02

Item no.: 8951089020

Low roller board: 115mm



- Only weights 4.8kg
- Cut-out arm area for more freedom of movement



Jack Stands

The UBZ range of safety stands is a must for every workshop when working on raised vehicles



Model	UBZ-2	UBZ-3	UBZ-6
Item number	8951000027	8951000028	8951000029
Load capacity	2 t	3 t	6 t
Min. height	280 mm	300 mm	400 mm
Max. height	425 mm	455 mm	620 mm
Stroke	145 mm	155 mm	220 mm
Weight	2.5 kg	3 kg	5 kg

Bottle jack

The hydraulic jacks of the Rodcraft MGN range can be used universally in the workshop and in the breakdown service

- Compact hydraulic jack with hand pump
- Stable welded construction and high stability due to the large base plate
- Maximum durability and resilience through double piston guide
- Safety valve to protect against overload.
- Can be used vertically or horizontally



Model	MGN2	MGN5	MGN12	MGN20	MGN30
Item number	8951000009	8951000011	8951000013	8951000014	8951000015
Load capacity	2 t	5 t	12 t	20 t	30 t
Min. height	178 mm	198 mm	176 mm	182 mm	280 mm
Max. height	347 mm	390 mm	347 mm	308 mm	445 mm
Stroke	169 mm	192 mm	171 mm	126 mm	165 mm
Weight	2.4 kg	3.8 kg	7.33 kg	9.1 kg	18.3 kg

Trolley jacks



Up to 2.5 tons load capacity



Model	RH136	RH151	RH201	RH251	RH216
Item number	8951000411	8951000051	8951000003	8951082024	8951000388
Load capacity	up to 1.5 t	1.5 t	2 t	2 t	2.5 t
Weight	14.3 kg	48.8 kg	20.5 kg	58 kg	32 kg
Min./max height	90 / 358 mm	78 / 540 mm	85 / 460 mm	135 / 800 mm	75 / 500 mm
Chassis length	485 mm	920 mm	695 mm	1,340 mm	685 mm

3 to 5 tons load capacity



Model	RH290	RH301	RH316	RH501
Item number	8951082031	8951082032	8951000458	8951082050
Load capacity	3 t	3 t	3 t	5 t
Weight	41.5 kg	70 kg	41 kg	95 kg
Min./max. height	145 / 490 mm	114 / 605 mm	95 / 520 mm	150 / 680 mm
Chassis length	650 mm	1320 mm	734 mm	1420 mm

* RH316 replaces model RH315

Air-hydraulic jacks

Air-hydraulic jack up to 20 t

Low compressed air requirement (300 l/min) for connection to truck braking system (only 7-10 bar required)

Model LHH22

Item no.: 8951084201

Load capacity: 20 t

Weight: 49 kg

Min./max. height: 210/435 mm

Chassis length: 430 mm



Air-hydraulic jack up to 30 t

Low profile and large lift. Faster and easier lifting – controlled via the valve on the hose: integrated pneumatically driven hydraulic pump without pumping by hand

Model LHH35

Item no.: 8951084350

Load capacity: 30 t

Weight: 54.4 kg

Min./max. height: 255/488 mm

Chassis length: 610 mm



Hydraulic jack up to 30 t

Ideal for trucks and buses thanks to the high lifting capacity. Quick and easy control via the handle. Low profile, easy to maneuver.

Model ATJ30-2

Item no.: 8951000269

Load capacity: 30 t

Weight: 38 kg

Min./max. height: 150 mm / 409 mm

Chassis length: 326 mm



Hydraulic jack up to 50 t

Ideal for trucks and buses thanks to the high lifting capacity. Stable frame, easy maneuvering.

Model ATJ50-3

Item no.: 8951000270

Load capacity: 50 t

Weight: 73 kg

Min./max. height: 160 mm / 472 mm

Chassis length: 555 mm

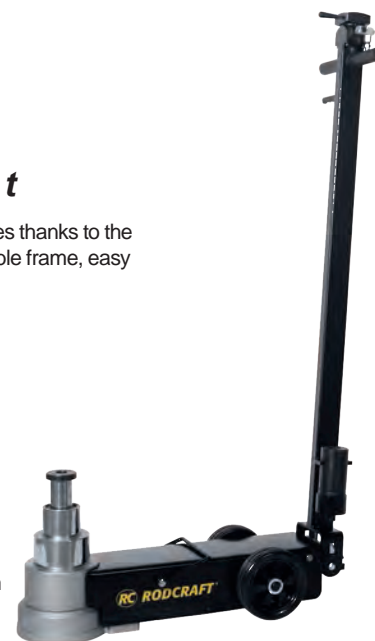

Wheel dollies

Model RHW1

Item no.: 8951089091

- Assembly aid for various wheel types/wheel sizes
- Adjustable support arms (29-62 cm)
- Hand lever with adjustable length (3 positions)
- Stop rollers for rim
- Max. load 250 kg



Wheel dollies

Model RG600

Item no.: 8951089045

Maximum load capacity 600 kg

- For tires up to 300 mm wide and with a maximum diameter of 650 mm
- Low weight of the gripper at only 18 kg



Transmission jack

Model	GHN600	GHN1000
Item number	8951000448	8951000449
Capacity (kg)	600 kg	1,000 kg
Min. height (mm)	1,180 mm	1,180 mm
Max. height (mm)	2,000 mm	2,010 mm
Weight (kg)	36.9 kg	48.1 kg
Amount of hydraulic oil	0.91 l	1.32 l

- High security, stability and easy positioning.
- Chromed cylinder in oil bath
- Large foot pedal for stepless load lifting
- Dead man's control



Workshop crane, up to 1 t Model WK1000

Item no.: 8951000166

- Extra flat extension arms, only 90 mm high
- 3 positions for flexible adjustment (load dependent)
- 360° rotatable crane hook with safety device
- Foldable extension arms with safety bolts for space-saving storage
- 200° pivoting hand pump with double piston
- Lowering valve with dead man's control



Hydraulic ram set – 4 t Model HRS04

Item no.: 8951000124

Hydraulic ram set – 10t Model HRS10

Item no.: 8951000125



- Fully hydraulic ram set
- Possible uses: Press - expand - clamp
- Simple assembly thanks to threadless connections
- 17 piece set in plastic case for easy storage
- Individually shaped compartment for each part, so that the set remains complete
- Including full set of accessories

Hydraulic ram set 20 t Model HRS20

Item no.: 8951000126



Fully hydraulic ram set – 20 t, incl. accessories set.

- All accessories in steel with threaded connection
- 2-stage hand pump for 700 bar working pressure
- In 2 robust metal boxes
- Hydraulic cylinder with 130 mm lift
- Hose length 1,500 mm (pump/cylinder)

Hydraulic ram set 10 t Model RGS100

Item no.: 8951089054

- Easy to move with oil and acid resistant plastic wheels
- Strong 8" 10 t hydraulic piston
- Pulling arm can be tilted sideways by 45°
- Precise pump control for smaller or more complicated directional work
- PHP10 is an ideal complement to save time and reduce manual effort

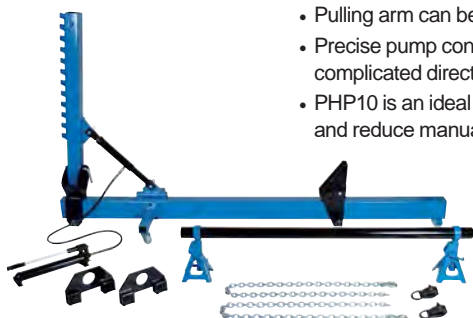

Pneumatic-hydraulic pump Model PHP10

Item no.: 8951000136



- Can be used with the hydraulic cylinders HRS04, HRS10 and HRS20
- For convenient and energy-saving hand or foot operation
- Maximum hydraulic pressure of 700 bar

Workshop presses

Hydraulic workshop presses are indispensable in the workshop and many industrial companies for special precision work, such as removing and replacing ball bearings, bending pipes or profiles or straightening bent parts. The professional presses can be bench mounted or installed on the floor with shims for perfect stability. Some of our hydraulic presses have various additional functions such as lateral cylinder adjustment, two speed levels - for fast approach and powerful pressing - and foot control.

New 2-speed automatic pump for WP15/WP20S/WP30P/WP50P
Easier to use, no need to change speed manually.

Model WP15

Item no.: 8951000064



15 tons

Model WP20S

Item no.: 8951000065



20 tons

Model WP30P

Item no.: 8951000071



30 tons

Model WP50P

Item no.: 8951000072



50 tons

Model WP75P

Item no.: 8951000170



75 tons

Model WP100P

Item no.: 8951000171



100 tons

Model	WP15	WP205S	WP30P	WP50P	WP75P	WP100P
Item number	8951000064	8951000065	8951000071	8951000072	8951000170	8951000171
Capacity	15 t	20 t	30 t	50 t	75 t	100 t
Height	882 mm	1,772 mm	1772 mm	1,830 mm	1,840 mm	1,830 mm
Width	700 mm	740 mm	795 mm	1,030 mm	1,140 mm	1,200 mm
Weight	75.5 kg	105 kg	167 kg	298 kg	498 kg	766 kg
Hydraulic stroke	160 mm	186 mm	160 mm	200 mm	250 mm	300 mm

Punch set Model DS8

Item no.: 8955000050

- 8 mandrels (10, 12, 16, 18, 20, 22, 25, 30 mm)
- Quick-change mount
- Perforated sheet
- Bracket

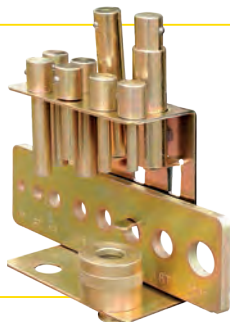



Quick-change mount with 8 mandrels suitable for Rodcraft workshop presses WP15, WP20S, WP30P, WP50P, WP75P and WP100P
 Allows quick mandrel changes and fits the piston of all workshop presses pictured above.

Plug nipples + quick couplings

<i>Item number</i>	<i>Designation</i>
 8951011809	Plug nipple with thread BSP 1/4" external thread
8951011810	Plug nipple with thread BSP 3/8" external thread
8951011811	Plug nipple with thread BSP 1/2" external thread
8951011812	Plug nipple with thread BSP 1/4" internal thread
 8951011813	Plug nipple with thread BSP 3/8" internal thread
8951011814	Plug nipple with thread BSP 1/2" internal thread
8951011795	Nipple ISO7, 2 mm, for hoses 6-7 mm
 8951011796	Nipple ISO7, 2 mm, for hoses 9 mm
8951011797	Nipple ISO7, 2 mm, for hoses 13 mm
8951011784	Quick coupling BSP 1/4" external thread
 8951011785	Quick coupling BSP 3/8" external thread
8951011786	Quick coupling BSP 1/2" external thread
8951011787	Quick coupling BSP 1/4" internal thread
 8951011788	Quick coupling BSP 3/8" internal thread
8951011789	Quick coupling BSP 1/2" internal thread
8951011790	Quick coupling for hoses 6-7 mm
 8951011791	Quick coupling for hoses 9-10 mm
8951011792	Quick coupling for hoses 13 mm
 8951011819	2-way distributor with quick coupling BSP 3/8" internal thread
8951011820	3-way distributor with quick coupling BSP 3/8" internal thread

PE pneumatic air hose with coupling Model PE pneumatic air hose

<i>Item number</i>	<i>Designation</i>
 8951011842	PUR Spiral hose, 8mm inner diameter and 4m long EUR7,2 coupling and nipple connector
8951011843	PUR Spiral hose, 8mm inner diameter and 6m long EUR7,2 coupling and nipple connector
8951011844	Length 8 m, Internal diameter 8 mm, External diameter 10 mm, max. working pressure 15 bar
8951011845	Spiral hose 6,5mm inner diameter with 1/4" AG thread Lenght 6m made from polyurethane PUR
 8951011846	Spiral hose 8mm inner diameter with 3/8" AG thread Lenght 6m made from polyurethane PUR
8951011847	Spiral hose 8mm inner diameter with 3/8" AG thread Lenght 4m made from polyurethane PUR
8951011848	Spiral hose 8mm inner diameter with 3/8" AG thread Lenght 8m made from polyurethane PUR

RODCRAFT FRL maintenance units: Cleaner air, full power

With the RODCRAFT maintenance unit, you extend the service life of your compressed air tools and reduce the energy requirement. Your tools are automatically set to the optimum oil quantity supplied and the filter provides protection against dirt and water

Maintenance unit – **connections 1/2"** Maintenance unit – **connection 1/4" BSP**
 Item no.: 8951000164 Item no.: 8951000162

- Stable aluminum housing with composite containers.
- 5-Micron filter
- Semi-automatic manual drain
- Max. inlet pressure 15 bar
- Max. air passage 2,080 l/min



Hose reel

With length adjustment, ratchet lock, swiveling wall bracket and all-round movable air connection

High-quality hose for all applications, lighter and more flexible than rubber. Latch spring locks the hose after unrolling and pulls it effortlessly with return power on again.

Rubber protection protects against stress on the crimp connections.

Drum spring: up to 20,000 - 25,000 cycles for excellent durability. Movable retraining ball allows adjustment of the minimum hose length.

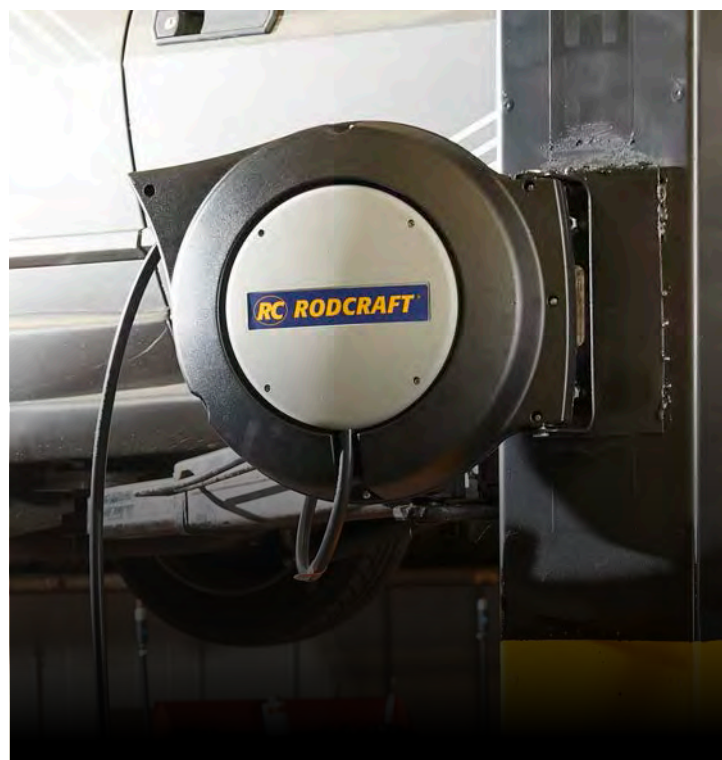

Model	SAR21	SAR22	SAR31	SAR32
Item number	8951000148	8951000149	8951000150	8951000151
Length	10 m	16 m	10 m	160 m
Internal diameter	8 mm	10 mm	8 mm	10 mm
Thread size	1/4" BSP	3/8" BSP	1/4" BSP	3/8" BSP
Hose material	Polyurethane			

Device oiler Model G1K

Item no.: 8951011851



Small oiler with a volume of 4 ml that is attached directly to the tool. 1/4" thread

Air oil RCA1000

Item no.: 8955000117

For the lubrication of pneumatic tools. Contains additives that constantly maintain the protective film against rust and corrosion

Air oil, 1,000 ml



- Very good flow properties at low temperatures
- Very good protection against corrosion
- High pressure and impact resistant
- Non-toxic



© 2024 Rodcraft. Subject to technical modifications.

RC RODCRAFT[®]

Changes, misprints and errors reserved
Prices on request, please contact your
preferred retailer or visit us at
www.rodcraft.com

Your retailer: